

ISUZU MOTORS SOUTH AFRICA WHEEL ALIGNMENT SPECIFICATIONS

Workshop manual

Description Driveline, Axle MUA/MUX/TB-50LS,
Functional Inspection, Wheel alignment check



Vehicle load: the vehicle should be loaded in a manner which simulates at least 75% of it's operating condition. Unless this is done, the vehicle may experience premature and uneven tyre wear.

Model	Axle		Degrees & Minutes	Decimal Degrees	Min	Max	Midpoint	Tolerance		
			For decimal degrees only							
ISUZU KB/D-MAX RTxx 6th Generation	FRONT	Trim Height (with under slung rear axle)	dimension b = 114 mm							
		Trim Height (with over slung rear axle)	dimension b = 140 mm							
		Toe (per side)	0° 04' to 0° 08'	0.07° to 0.14°	0.07	0.14	0.11	0.04		
		Toe (total)	0° 08' to 0° 16'	0.14° to 0.28°	0.14	0.28	0.21	0.07		
		Camber	-0° 30' to 0° 30'	-0.50° to 0.50°	-0.50	0.50	0.00	0.50		
			Difference between left and right must not exceed ±0° 30'	Difference between left and right must not exceed ±0.50°						
		Caster	With under slung rear axle (low ride suspension)		2° 51' to 4° 21'	2.85° to 4.35°	2.85	4.35	3.60	0.75
			With over slung rear axle (high ride suspension)		2° 33' to 4° 03'	2.55° to 4.05°	2.55	4.05	3.30	0.75
			Difference between left and right must not exceed ±0° 30'	Difference between left and right must not exceed ±0.50°						
		KPI	12° 00' to 13° 00'	12.00° to 13.00°	12.00	13.00	12.50	0.50		
		REAR	Toe (per side)	-0° 10' to 0° 10'	-0.17° to 0.17°	-0.17	0.17	0.00	0.17	
			Toe (total)	-0° 20' to 0° 20'	-0.34° to 0.34°	-0.34	0.34	0.00	0.34	
			Camber	-0° 15' to 0° 15'	-0.25° to 0.25°	-0.25	0.25	0.00	0.25	
Thrust angle	-0° 21' to 0° 21'		-0.35° to 0.35°	-0.35	0.35	0.00	0.35			

2WD (Except high ride suspension specifications)

Buffer clearance (Reference value)	25.9 mm { 1.02 in }
Trim height (Reference value)	114 mm { 4.5 in }

2WD (Except high ride suspension specifications)

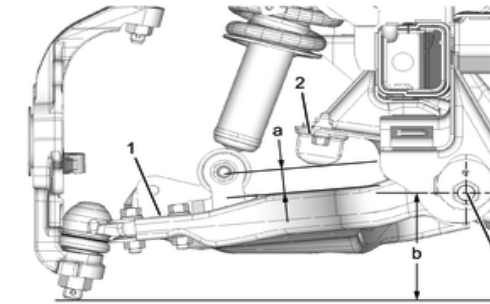

RTWJ3CSH000901

Legend

- 1. Lower link
- 2. Bumper rubber
- 3. Rear cam bolt center

Legend

- a. Buffer clearance
- b. Trim height

2WD (High ride suspension specifications), 4WD

Buffer clearance (Reference value)	26 mm { 1.02 in }
Trim height (Reference value)	140 mm { 5.5 in }

2WD (High ride suspension specifications), 4WD

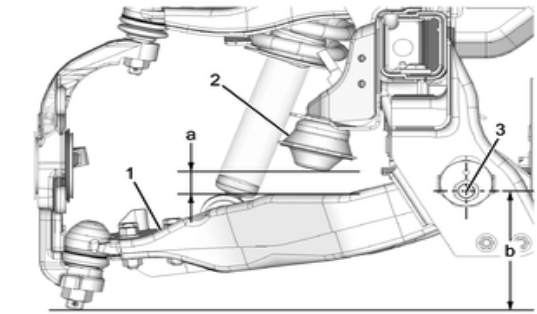

RTWJ3CSH001001

Legend

- 1. Lower link
- 2. Bumper rubber
- 3. Rear cam bolt center

Legend

- a. Buffer clearance
- b. Trim height